

F-22A

20mm gatling gun system

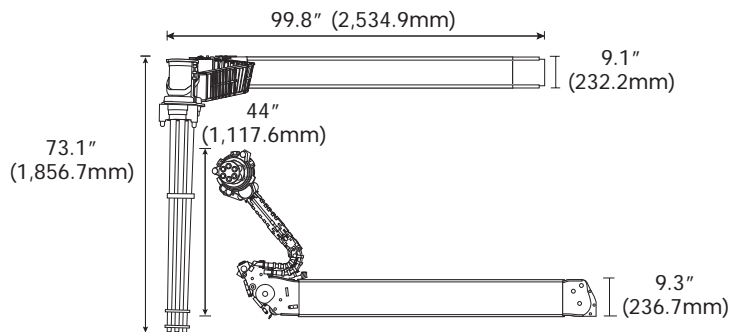

Specifications

Gun type	M61A2, six-barrel, 20mm, externally powered Gatling gun system
Weight (total)	648 pounds (294 kg)
Gun	202 pounds (91.6 kg)
Feed system	176 pounds (80 kg)
Ammunition (full)	270 pounds (122.5 kg)
Rate of fire	6,000 shots per minute
Ammunition capacity	480 rounds
Ammunition type	Compatible with all NATO standardized agreement 3585 ammunition
Feed system	Linear linkless, closed loop
Drive system	Hydraulic

The F-22A fighter is armed with the M61A2 20mm Gatling gun system produced by General Dynamics Armament and Technical Products. The fixed-forward internal gun system provides maximum firing rate performance.

The F-22A armament system features the lightweight M61A2 20mm Gatling gun and linear linkless ammunition feed system. The M61A2 provides up to 10 times the reliability of single-barrel guns, firing at 6,000 shots per minute and placing a controlled dispersion of projectiles in the path of the target.

The linear linkless ammunition feed system features state-of-the-art composite and unique gun-feed technologies to provide high reliability at minimum weight. GDATP ammunition storage and handling systems have been used in all modern U.S. front-line fighter aircraft.

The F-22A linear linkless ammunition feed system is compatible with three GDATP loading systems, including the Universal Ammunition Loading System, the Ammunition Loading System and the Universal Delinking Loader. The ALS and UALS systems significantly reduce manpower requirements and aircraft turnaround time by eliminating the need for linked ammunition.

GENERAL DYNAMICS

Armament and Technical Products

Four LakePointe Plaza, 2118 Water Ridge Parkway, Charlotte, NC 28217 ■ www.gdatp.com
Tel 704 714 8000 ■ Fax 704 714 8232 ■ E-mail GDBusDev@gdatp.com