

# F-16

## 20mm gatling gun system



The F-16 fighter is armed with a 20mm Gatling gun system produced by General Dynamics Armament and Technical Products. This fixed-forward firing system provides maximum lethality against air-to-air and air-to-surface targets.

The weapon system features the M61A1 six-barrel Gatling gun and a linkless ammunition feed system. The M61A1 provides up to 10 times the reliability of single-barrel guns, firing at 6,000 shots per minute and placing a controlled dispersion of projectiles in the path of the target. Over 4,500 F-16 systems have been delivered to date.

The double-ended linkless ammunition feed system incorporates a compact lightweight composite rotary ammunition drum to store unfired and fired ammunition. The feed system is compatible with four GDATP loading systems: the Universal Ammunition Loading System; the Ammunition Loading System; the F-16 Delinking Loader and the Universal Delinking Loader. The ALS and UALS systems significantly reduce manpower requirements and turnaround time by eliminating the need for linked ammunition.

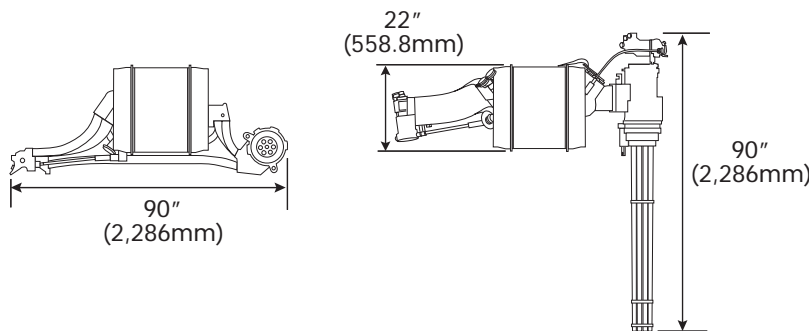

### Specifications

Gun type	M61A1, six-barrel, 20mm, externally powered Gatling gun
Weight (total)	832 pounds (377 kg)
Gun	248 pounds (112.5 kg)
Feed system	258 pounds (117 kg)
Ammunition (full)	325 pounds (147 kg)
Rate of fire	6,000 shots per minute
Ammunition capacity	511 rounds
Ammunition type	M50- & PGU-series ammunition
Feed system	Rotary, linkless, closed loop
Drive system	Hydraulic

## GENERAL DYNAMICS

Armament and Technical Products

Four LakePointe Plaza, 2118 Water Ridge Parkway, Charlotte, NC 28217 ■ [www.gdatp.com](http://www.gdatp.com)

Tel 704 714 8000 ■ Fax 704 714 8232 ■ E-mail [GDBusDev@gdatp.com](mailto:GDBusDev@gdatp.com)